



NEXUS 605RS/RSB



NEXUS 605RS/RSB Rockwell/Superficial Rockwell/Brinell hardness tester



General information

The NEXUS 605 models are a new generation of hardness testing instruments. The testers main body is a fine casted rigid structure which incorporates a load cell, closed loop force actuator that provides continuous force feedback information. The load application system avoids “overshoot” during the test force application and guarantees one of the best GR & R results ever seen on Rockwell/Brinell hardness testers in this class. The tester meets or exceeds the ISO, ASTM and JIS standards. (ISO 6508, ASTM E18, ASTM B254, JIS Z2245)

Test forces range from 2.5kgf/24.5N to 187.5kgf/1838N, Advanced algorithms, digital filter technology and state of the art electronics provide a very reliable and robust Rockwell hardness tester. NEXUS stands for Next Generation.

The unique machine design allows Rockwell, Superficial Rockwell and Brinell load settings. The NEXUS 605 RS/RSB model makes it possible to perform hardness tests in Rockwell and Superficial Rockwell scales and optionally (605RSB) can provide Brinell hardness testing. Models RSB are supplied with a separate Brinell measuring microscope.

Features

- Load cell, force feedback, closed loop system
- Excellent accuracy, best in class GR & R
- Load range 2.5kgf/24.5N up to 187.5kgf/1838N (depending on model)
- Fully automatic operation
- Meets or exceeds ISO, ASTM and JIS standards
- Shape correction settings for curved surfaces
- Go/No Go function with color full visual and acoustic warning
- Large memory for test results storage
- Easy calibration function
- Testing program storage
- Standard workpiece clamping attachment
- Connectivity USB-2
- External Brinell microscope (RSB model)
- Large workpiece accommodation

Technical specifications

NEXUS 605RS/RSB

Hardness scales RS	Rockwell and Superficial Rockwell all scales
Hardness scales RSB	Rockwell, Superficial Rockwell and all Brinell scales (2.5kgf/24.5N to 187.5kgf/1838N)
Load application	Load cell, force feedback, closed loop system
Rockwell Pre load	3kgf and 10kgf
Rockwell main load	15kgf, 30kgf, 45kgf, 60kgf, 100kgf, 150kgf
Rockwell test scales	A, B, C, D, E, F, G, H, K, L, M, P, R, S, V
Superficial Rockwell scales	15N, 30N, 45N, 15T, 30T, 45T, 15W, 30W, 45W, 15X, 30X, 45X, 15Y, 30Y, 45Y
Brinell test load (RSB model)	2.5kgf/24.5N to 187.5kgf/1838N
Brinell test scales (RSB model)	HB1: 2.5kgf/24.5N, 5kgf/49N, 10kgf/98N, 30kgf/295N HB 2.5: 6.25kgf/61.29N, 15.625kgf/153.2N, 31.25kgf/306.45N, 62.5kgf/612N, 187.5kgf/1838N HB5: 25kgf/245.16N, 62.5kgf/612N, 125kgf/1225N HB10: 100kgf/980.7N
Display	Full color multi-function 6,5" industrial touch screen
Display overview	Conversion to other hardness scales such as Brinell, Vickers, Leeb, UTM. convex adjustment, machine settings, calibration
Standards	Meets or exceeds ISO, ASTM, JIS standards
Test cycles	Motorized, fully automatic, Pre load, Load, Dwell, Unload process
Indentors	Rockwell Diamond Cone: 120° Rockwell balls: 1/16", 1/8", 1/4", 1/2" Rockwell balls: 1/16", 1/8", 1/4", 1/2"
Dwell time	Brinell Balls: 1mm, 2.5mm, 5mm, 10mm Pre-load 1-99 seconds, Main load 1-99 seconds, Recovery 1-99 seconds
Connectivity	USB-2
Optical system RSB	Brinell microscope
Workpiece accommodation	Vertical capacity 250mm Horizontal capacity 170mm (from indenter center-line)
Operating temperature	10°C to 35°C, non-condensing
Machine dimensions	220mm x 540mm x 855mm (WxDxH)
Machine weight	82kg
Power supply	100V AC to 240V AC, 50Hz/60Hz, single phase

Standard delivery

- V-anvil
- Flat anvil 60mm
- Round testing table 150mm
- Brinell microscope (RSB)
- Power cable
- Four adjustable feet
- INNOVATEST® certificate
- Installation and user manual
- Pre-installed (plug and play)

Optional accessories

- Certified indentors (ASTM, DIN, ISO)
- Certified reference hardness blocks (ASTM, DIN, ISO)
- Custom testing tables
- Precision vice for small parts, jaw width 36mm
- Precision vice for small parts, jaw width 42mm
- Precision vice for small parts, jaw width 75mm
- V-blocks and special clamps
- Manual X-Y stage 100mm x 60mm, micrometer travel 25mm x 25 mm
- Solid tester table and storage cabinet



Order details

NEXUS 605RS

Rockwell, Superficial Rockwell all scales
test forces 3kgf/29.4N to 150kgf/1471N

NEXUS 605RSB

Rockwell, Superficial Rockwell, Brinell all scales
test forces 2.5kgf/24.5N to 187.5kgf/1838N (for Brinell)

Technical drawing NEXUS 605RS/RSB

All dimensions are in mm

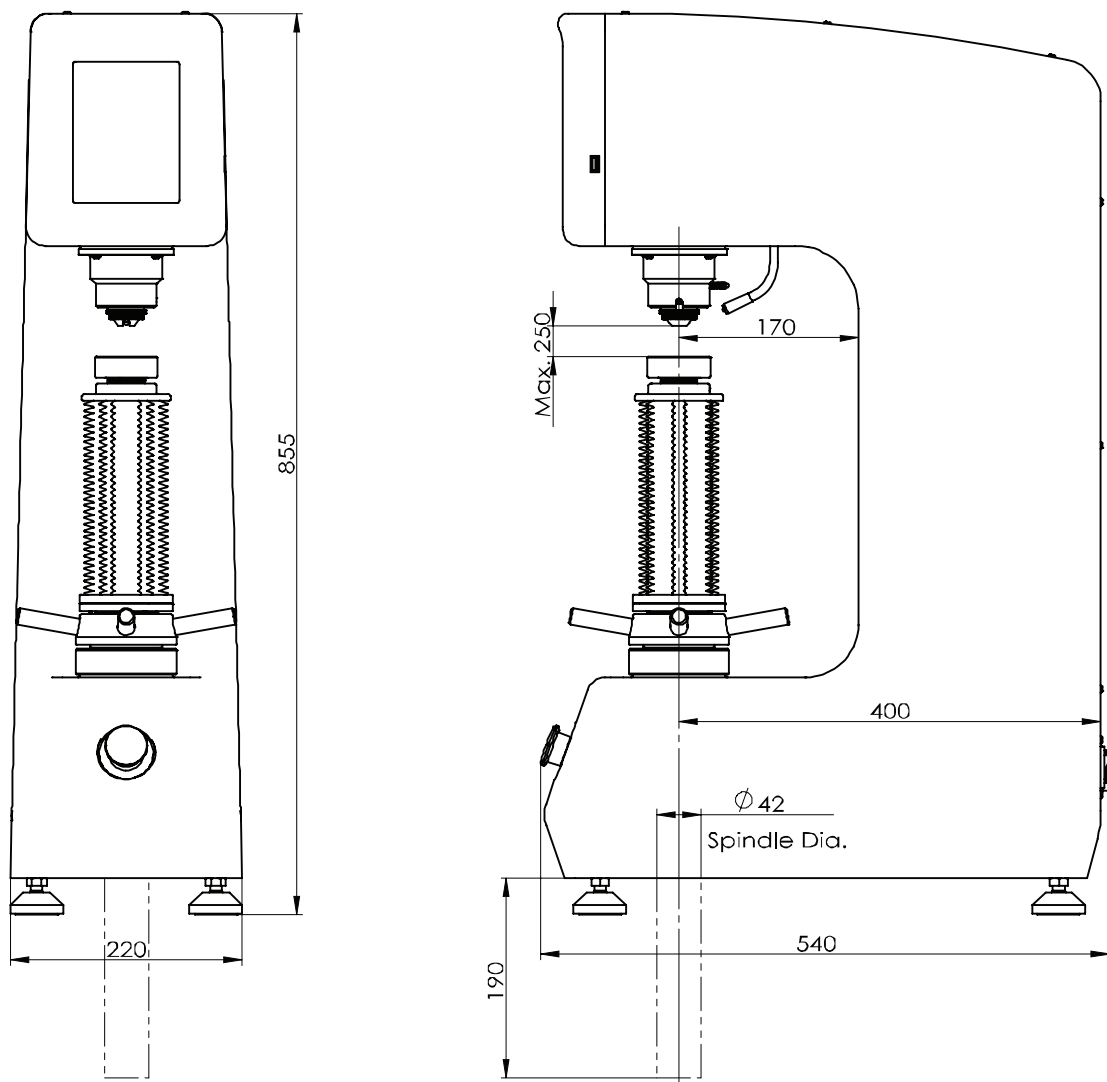

All dimensions are in mm

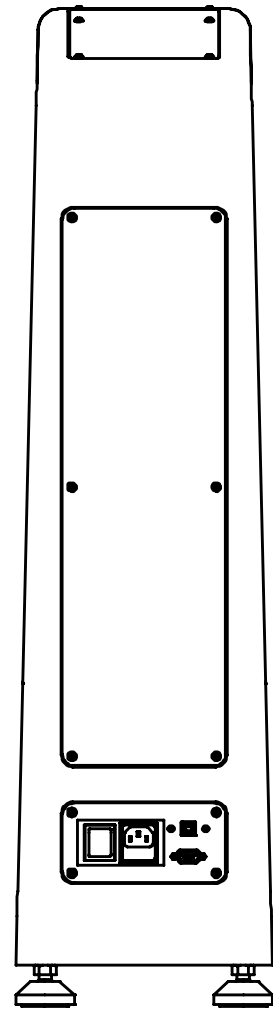
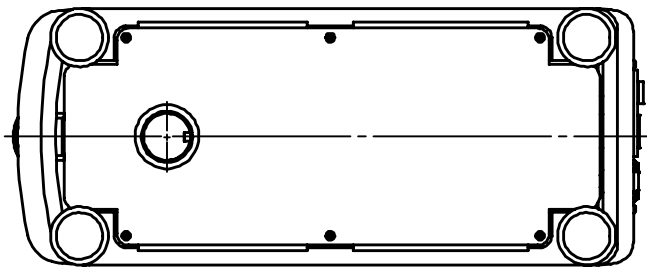

Represented by:

CORPORATE HEAD OFFICE

INNOVATEST Europe BV
MANUFACTURING, DISTRIBUTION & SERVICE

Borgharenweg 140
6222 AA Maastricht (The Netherlands)
Phone: +31 43 3520060
Fax: +31 43 3631168
E-mail: info@innovatest-europe.com
Website: www.innovatest-europe.com

INNOVATEST Shanghai Co., Ltd.
DISTRIBUTION, SALES & SERVICE

Building 2, No.123, 1165 Nong Jindu Road,
South Metropolis Industrial Park
Minhang District, Shanghai, P.R. China
Zip code: 201108
Phone: +86 21 60906200
Fax: +86 21 60912595
E-mail: info@innovatest-shanghai.com
Website: www.innovatest-shanghai.com

INNOVATEST SOUTH EAST ASIA
CUSTOMER SUPPORT CENTER

(c/o LMS Technologies Pte Ltd)
20 Sin Ming Lane #05-58 Midview City
Singapore 573 968
Phone: +65 6451 1123
Fax: +65 6452 1011
E-mail: info@lmstech.com.sg
Website: www.lmsscientific.com

Changes in products and/or product specifications can emerge due to new technologies and continuous development. We reserve the right to change or modify specifications of products without prior notice. We recommend you to contact our sales office for up-to-date information. © All rights reserved